



Wilkinson Star Technical

Jasic Cut 160

P150LT Plasma Hand Torch Manual

JASIC Contents Page

Index	Page Number
Jasic Cut 160 with P150LT Plasma Torch Overview	3
P150LT Consumable Breakdowns	4
P150LT Torch Information	9
Machine torch option	11
Safety Information	12
General Plasma Cutting Information	13
Stand-off Cutting	14
Drag Cutting	15
Piercing	16
Bevelling	16
Gouging	17
Plasma Cutting Tips and Techniques	18
Plasma Machine Gas Supply - Compressed Air	19
Contact Details	20



Before starting any cutting activity thoroughly read the operating manual first to familiarize yourself with the safe and correct operation of your Jasic plasma machine. Always ensure that you have suitable eye protection and protective clothing. Also take the necessary steps to protect any persons within the cutting area.



Jasic Cut 160 Plasma Cutting Machine supplied with P150LT 6m Plasma Hand Torch

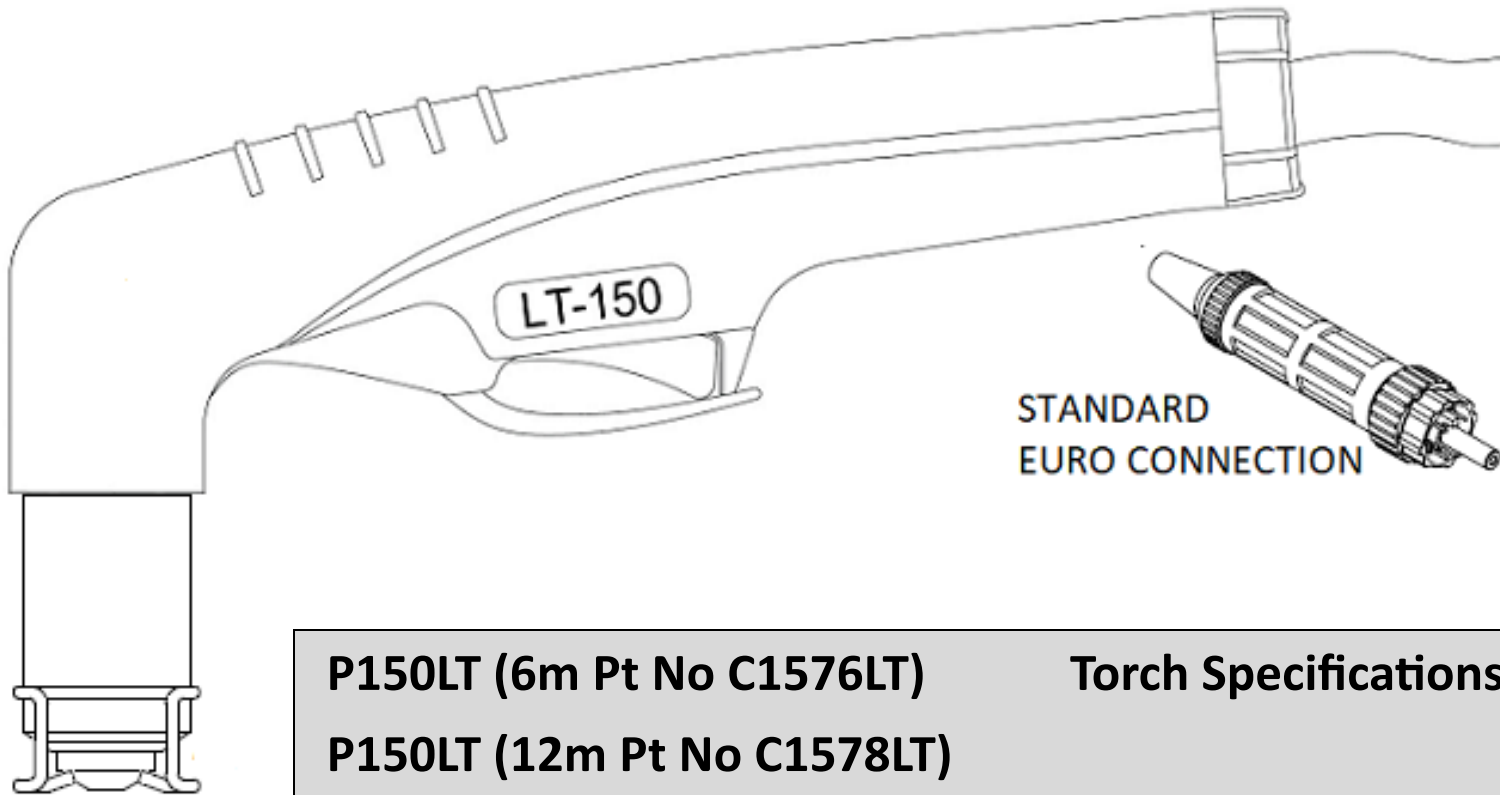

P150LT (6m Pt No C1576LT) P150LT (12m Pt No C1578LT)		Torch Specifications
Duty Cycle :	150 Amps at 60%	
Gas Air Pressure - Cutting :	76-80 PSI (4.8 - 5.0 bar)	
Gas Air Flow :	466 SCFH (220 lpm)	
Pilot Arc Ignition :	HF	



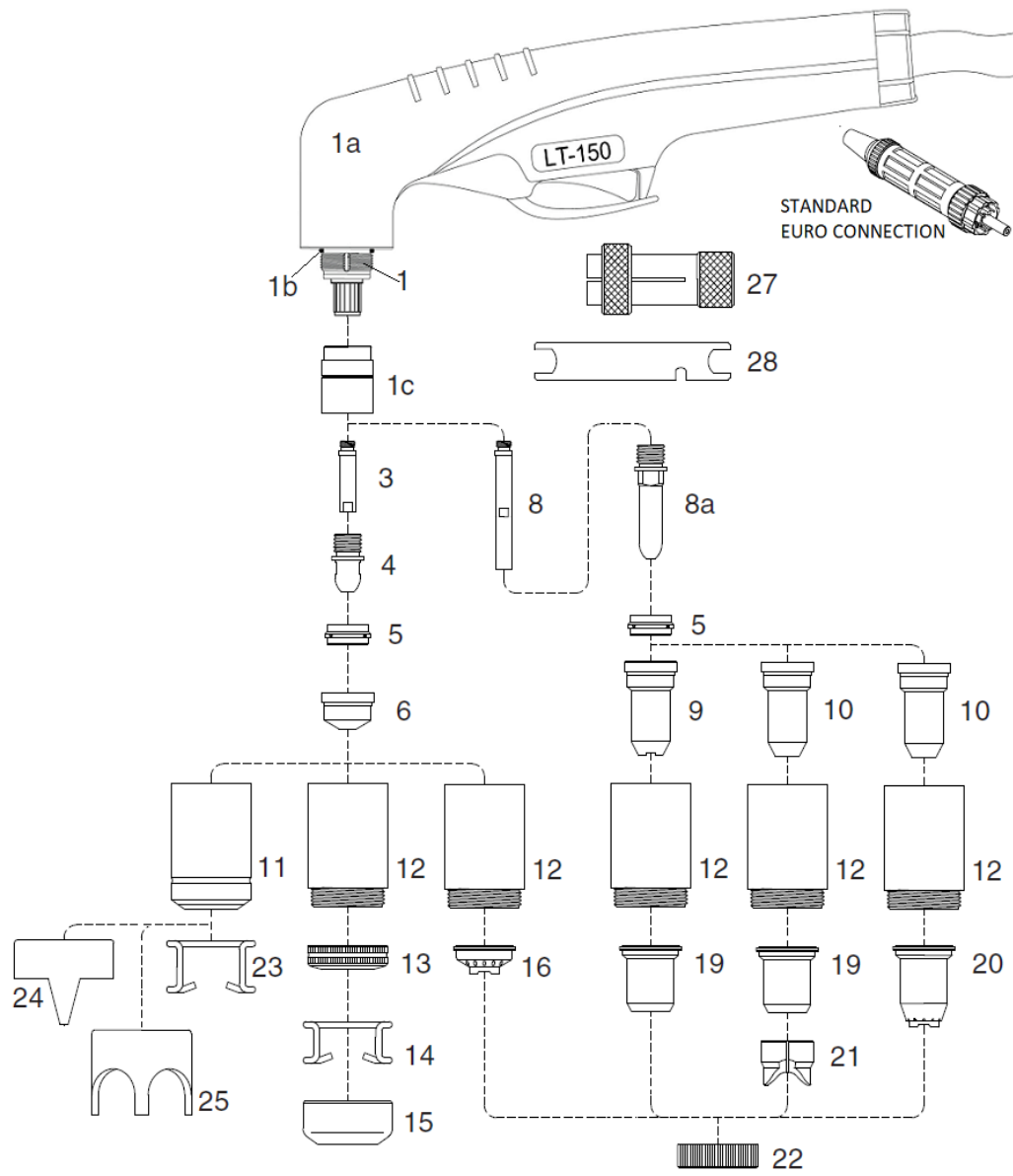

Item No	Part Number	Description	Pack Qty
1	02001	P150LT Torch Head (hand)	1
1a	09706	P150LT Handle c/w Switch	1
1b	C1398	'O' Ring - Torch Head	5
1c	C1017	Front Insulator - Vespel	1
3	C1378	Diffuser	1
4	C1376	Electrode Hafnium	4
5	C1377	Swirl Ring Vespel	1
6	C1371	Cutting Tip 1.1mm 60A	10
6	C1372	Cutting Tip 1.35mm 90A	10
6	C1373	Cutting Tip 1.6mm 120A	10
6	C1374	Cutting Tip 1.8mm 150A	10
6	WB300128	Gouging Tip 2.4mm 100A	10
6	C1375	Gouging Tip 3.0mm 150A	10
8	C1018	Extended Diffuser	1
8a	C1517	Extended Electrode	5
9	C1369	Extended Tip - Max 50A	10
10	C1001	Extended Tip 1.35 - 90A	10
10	C1002	Extended Tip 1.6 - 120A	10
10	C1003	Extended Tip 1.8 - 150A	10
11	C1389	Nozzle Retaining Cap	1
12	C1393	Contact Nozzle Retaining Cap	1
13	C1007	Spring Holder Protection Nut	1
14	C1008	Stand Off Spring (for C1389)	5
15	C1009	Gouging Spacer	1
16	C1010	Spacer for Contact Cutting (use with items 6, 12 & 22)	1
19	C1014	Shield Cup - Max 50A	1
20	C1015	Spacer for Contact Cutting	1
21	C1020	Spacer for Extended Tips (90A and above)	1
22	C1016	Locking Nut	1
23	C1386	Stand Off Spring	5
24	C1408	Double Pointed Spacer	1
25	C1409	Crown Spacer	1
27	C1509	Extractor for Swirl Ring	1
28	C3045012	Wrench for Electrode	1





Jasic Cut 160 Plasma Machine with P150LT Hand Torch

Stand-off cutting setup

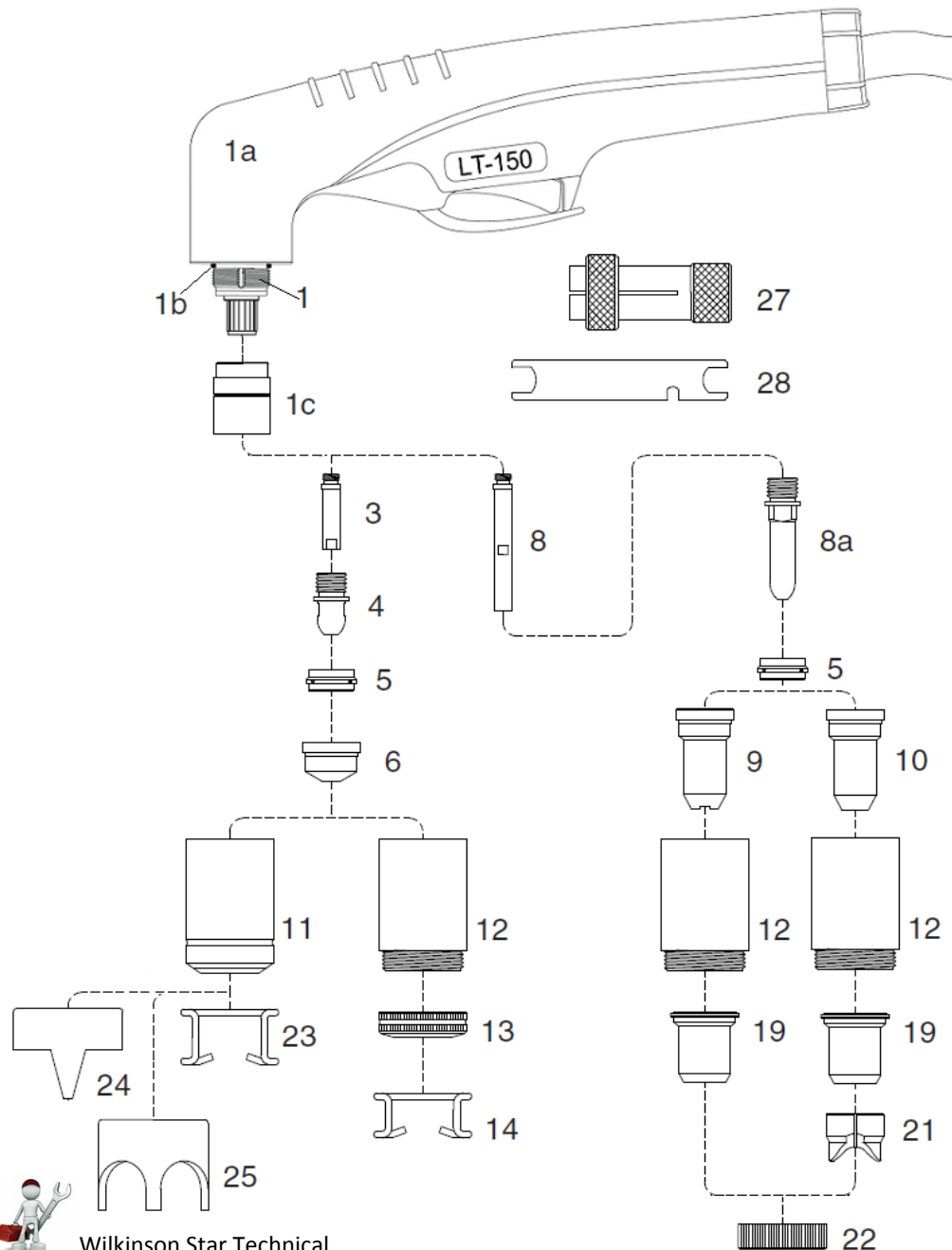

Item No	Part Number	Description	Pack Qty
1	02001	P150LT Torch Head (hand)	1
1a	09706	P150LT Handle c/w Switch	1
1b	C1398	'O' Ring - Torch Head	5
1c	C1017	Front Insulator - Vespel	1
3	C1378	Diffuser	1
4	C1376	Electrode Hafnium	5
5	C1377	Swirl Ring Vespel	1
6	C1371	Cutting Tip 1.1mm 60A	10
6	C1372	Cutting Tip 1.35mm 90A	10
6	C1373	Cutting Tip 1.6mm 120A	10
6	C1374	Cutting Tip 1.8mm 150A	10
8	C1018	Extended Diffuser	1
8a	C1517	Extended Electrode	5
9	C1369	Extended Tip—Max 50A	10
10	C1001	Extended Tip 1.35 - 90A	10
10	C1002	Extended Tip 1.6 - 120A	10
10	C1003	Extended Tip 1.8 - 150A	10
11	C1389	Nozzle Retaining Cap	1
12	C1393	Contact Nozzle Retaining Cap	1
13	C1007	Spring Holder Protection Nut	1
14	C1008	Stand Off Spring (for C1389)	5
19	C1014	Shield Cup - Max 50A	1
21	C1020	Spacer for Extended Tips (90A and above)	1
22	C1016	Locking Nut	1
23	C1386	Stand Off Spring	5
24	C1408	Double Pointed Spacer	1
25	C1409	Crown Spacer	1
27	C1509	Extractor for Swirl Ring	1
28	C3045012	Wrench for Electrode	1





Jasic Cut 160 Plasma Machine with P150LT Hand Torch

Exposed tip contact cutting setup

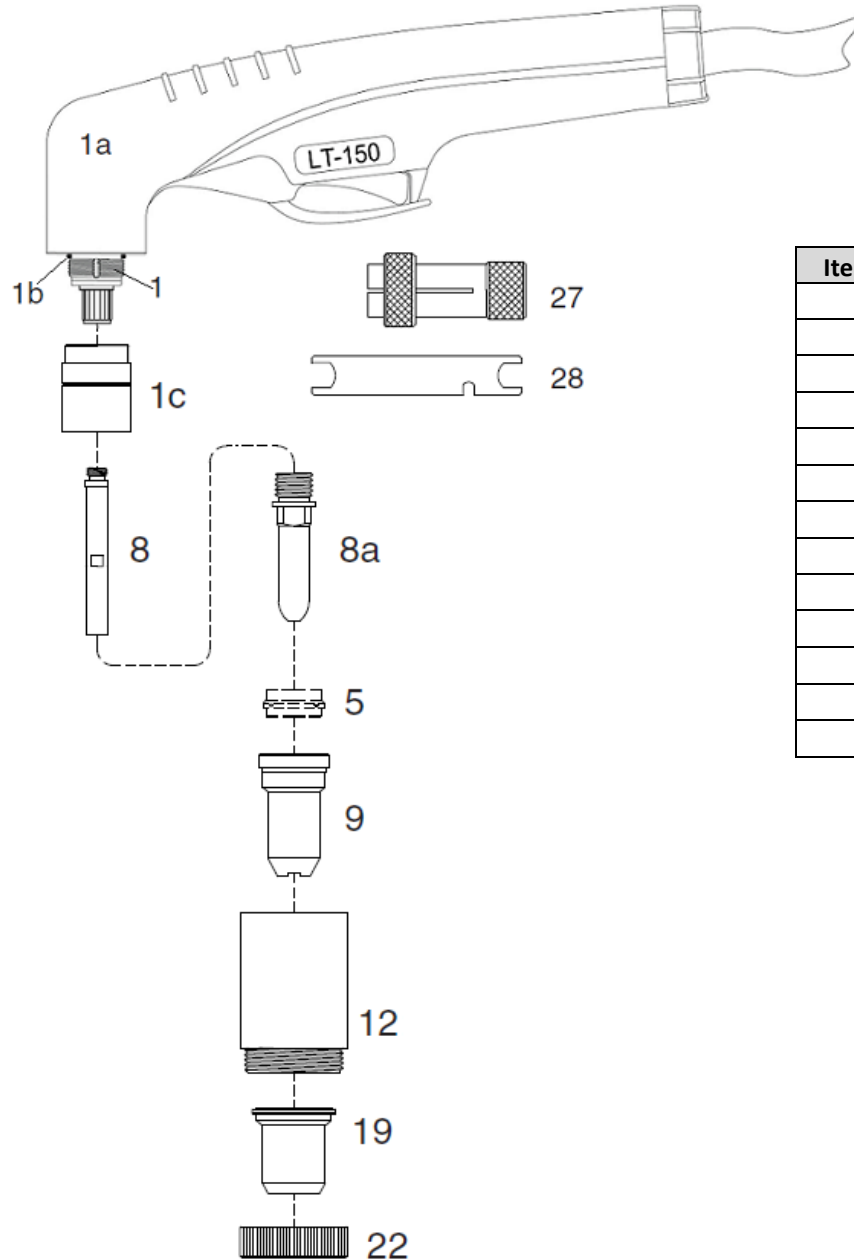

Item No	Part Number	Description	Pack Qty
1	02001	P150LT Torch Head (hand)	1
1a	09706	P150LT Handle c/w Switch	1
1b	C1398	'O' Ring - Torch Head	5
1c	C1017	Front Insulator - Vespel	1
5	C1377	Swirl Ring Vespel	1
8	C1018	Extended Diffuser	1
8a	C1517	Extended Electrode	5
9	C1369	Extended Tip - Max 50A	1
12	C1393	Contact Nozzle Retaining Cap	1
19	C1014	Shield Cup - Max 50A	1
22	C1016	Locking Nut	1
27	C1509	Extractor for Swirl Ring	1
28	C3045012	Wrench for Electrode	1





Jasic Cut 160 Plasma Machine with P150LT Hand Torch

Enclosed tip drag cap cutting setup

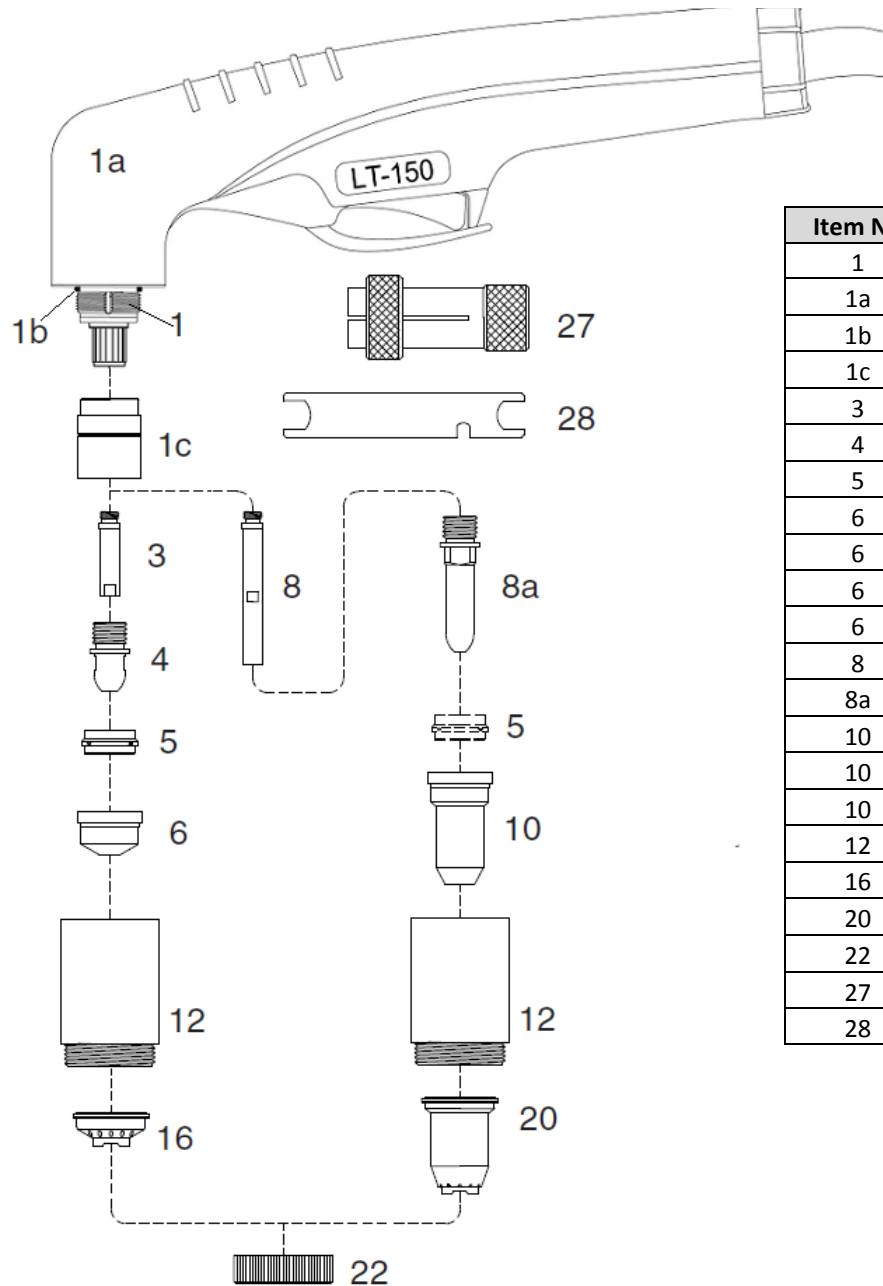

Item No	Part Number	Description	Pack Qty
1	02001	P150LT Torch Head (hand)	1
1a	09706	P150LT Handle c/w Switch	1
1b	C1398	'O' Ring - Torch Head	5
1c	C1017	Front Insulator - Vespel	1
3	C1378	Diffuser	1
4	C1376	Electrode Hafnium	5
5	C1377	Swirl Ring Vespel	1
6	C1371	Cutting Tip 1.1mm 60A	10
6	C1372	Cutting Tip 1.35mm 90A	10
6	C1373	Cutting Tip 1.6mm 120A	10
6	C1374	Cutting Tip 1.8mm 150A	10
8	C1018	Extended Diffuser	1
8a	C1517	Extended Electrode	5
10	C1001	Extended Tip 1.35 - 90A	10
10	C1002	Extended Tip 1.6 - 120A	10
10	C1003	Extended Tip 1.8 - 150A	10
12	C1393	Contact Nozzle Retaining Cap	1
16	C1010	Spacer for Contact Cutting (use with items 6, 12 & 22)	1
20	C1015	Spacer for Contact Cutting	1
22	C1016	Locking Nut	1
27	C1509	Extractor for Swirl Ring	1
28	C3045012	Wrench for Electrode	1



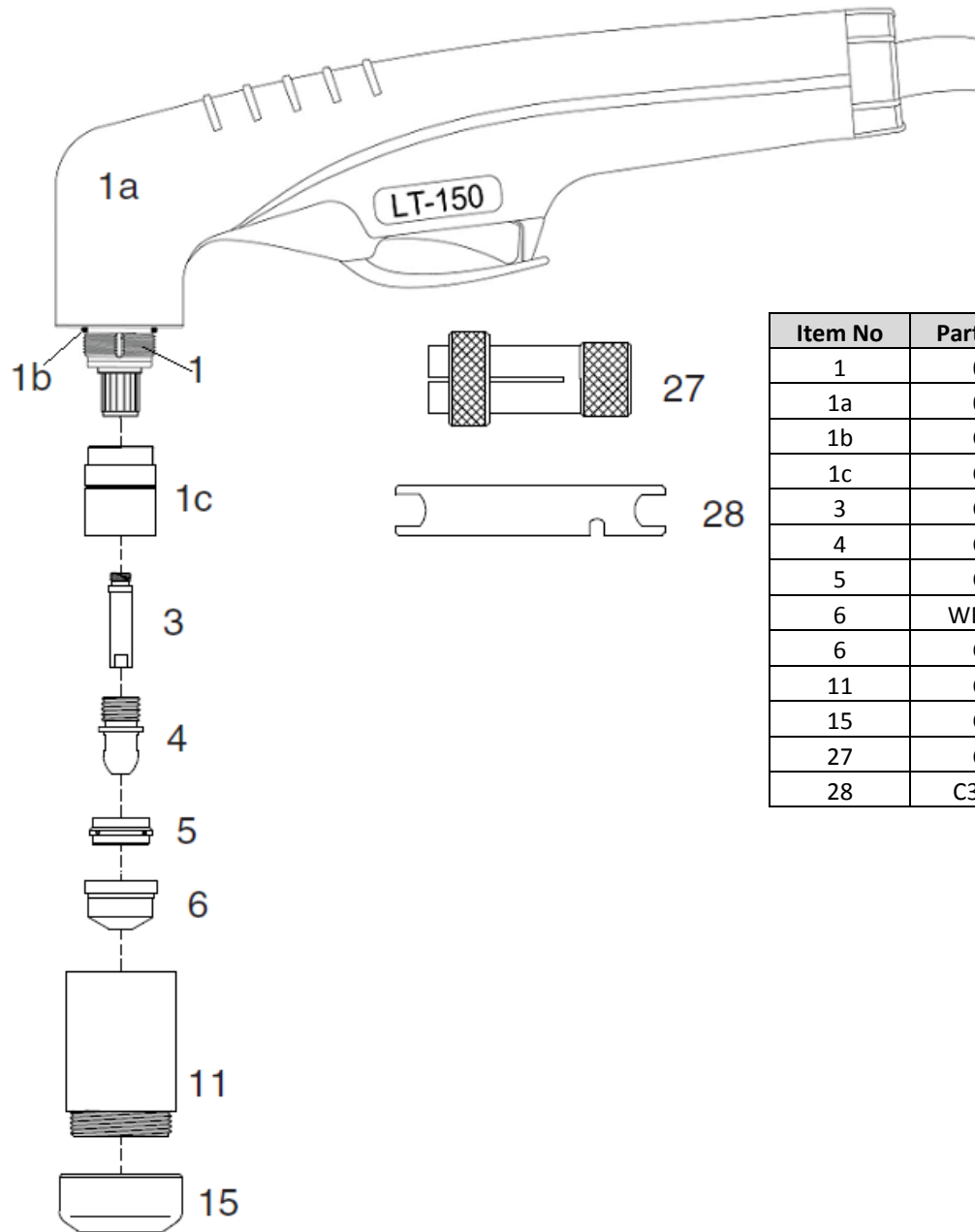

Item No	Part Number	Description	Pack Qty
1	02001	P150LT Torch Head (hand)	1
1a	09706	P150LT Handle c/w Switch	1
1b	C1398	'O' Ring - Torch Head	5
1c	C1017	Front Insulator - Vespel	1
3	C1378	Diffuser	1
4	C1376	Electrode Hafnium	5
5	C1377	Swirl Ring Vespel	1
6	WB300128	Gouging Tip 2.4mm 100A	10
6	C1375	Gouging Tip 3.0mm 150A	10
11	C1389	Nozzle Retaining Cap	1
15	C1009	Gouging Spacer	1
27	C1509	Extractor for Swirl Ring	1
28	C3045012	Wrench for Electrode	1



JASIC P150LT Plasma Hand Torch

The P150LT plasma torch supplied has the 'euro style' power/gas connection, pilot cable and switch pins connections.

All Jasic plasma cutting systems and torches supplied incorporate a safety circuit to prevent operator injury when changing consumables etc. This is a simple ring circuit that breaks the electrical torch switching as soon as the retaining cap is removed preventing machine operation. Without such a protection circuit as previously mentioned the open circuit voltage could be as high as 350V DC at the torch head.

The torch head encompasses a full set of consumables as shown right, these consumables are made up of a cooling tube, torch electrode, swirl ring for gas distribution, cutting tip, retaining cap and if required a stand off device to ensure the same distance between tip and material being cut.

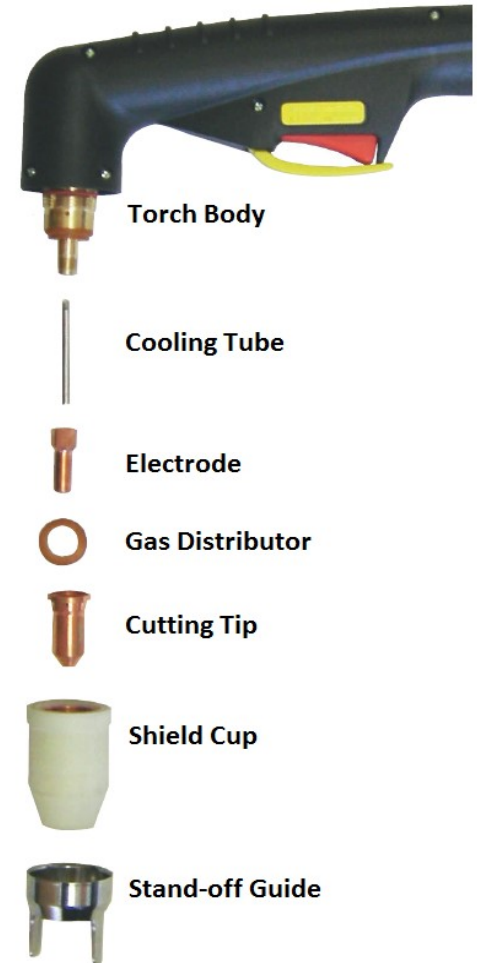

Plasma Torch Connection Diagram

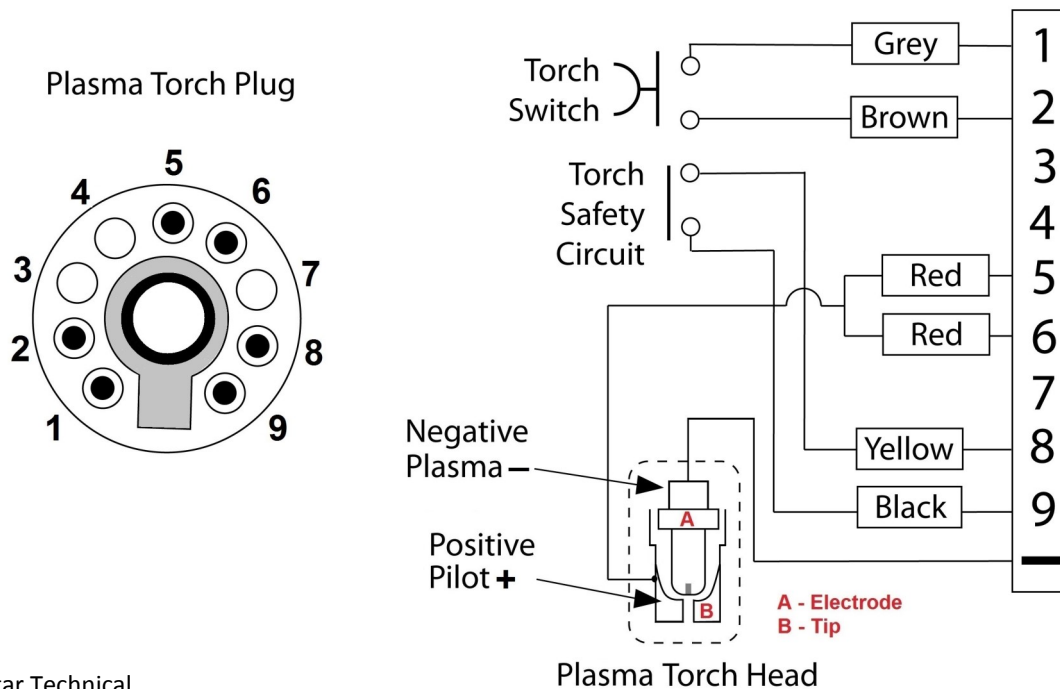

JASIC P150LT Plasma Hand Torch

Fitting the P150LT plasma torch

On the Jasic Cut 100 plasma machine, the below torch fitting instructions will need to be observed.

- Locate plasma torch plug into euro connector socket as shown in (Fig 1) image below
- While using the key provided (Fig 6)
- Push and hold in button in (Fig 2) whilst at the same time rotating the nut clockwise until fully connected and tight as shown in Fig 3
- Fig 4 shows the torch screwed in correctly
- Fig 5 shows the torch not fully connected in place

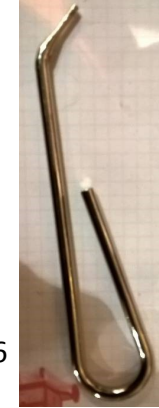

Fig 6



Fig 1



Fig 2



Push button



Fig 3



Fig 4

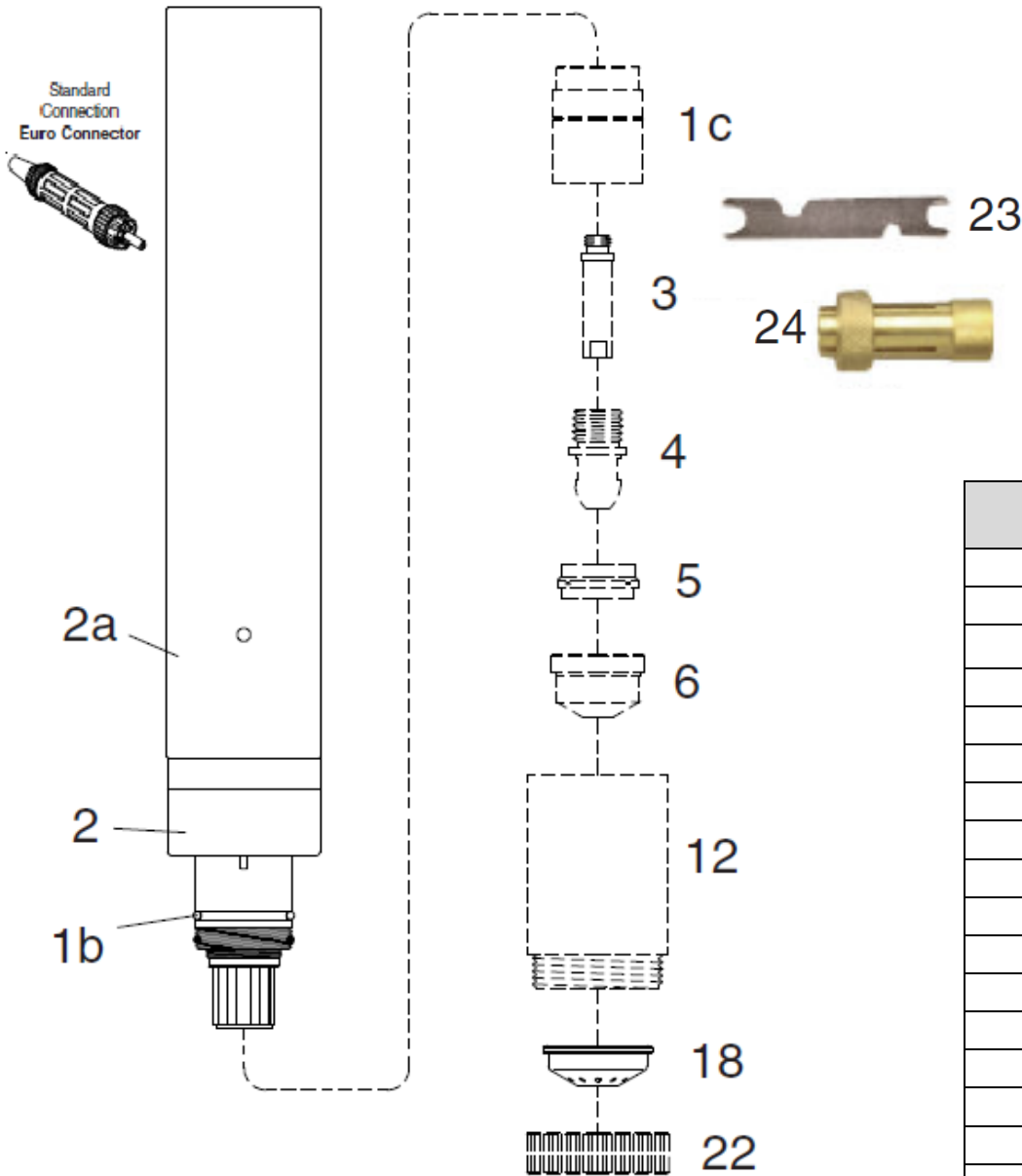

Fig 5



Plasma Machine Torch - PM150LT 6m - Euro (Pt No C1577)

PM150LT 12m - Euro (Pt No C1579)



Current :	50 - 150 Amps
Duty Cycle :	150 Amps at 60%
Gas :	Air
Gas Pressure - Cutting :	72-87 PSI (5.0-6.0 bar)
Gas Flow @ 125A :	466 SCFH (220 lpm)
Post Flow Time :	45 Seconds
Pilot Arc Current :	15 - 22 Amps
Pilot Arc Ignition :	HF

Item No	Part Number	Description	Pack Qty
1b	C1398	Torch Head 'O' Ring	1
1c	C1017	Front Insulator	1
2	C1354	Torch Head	1
2a	C3055623	Machine Torch Handle	1
3	C1378	Air Diffuser	1
4	C1376	Electrode Hafnium	5
5	C1377	Swirl Ring (Vespel)	1
6	C1371	Cutting Tip (1.1mm) 60A	10
6	C1372	Cutting Tip (1.35mm) 90A	10
6	C1373	Cutting Tip (1.6mm) 120A	10
6	C1374	Cutting Tip (1.8mm) 150A	10
12	C1393	Contact Retaining Cap	1
12	C1006	Contact Retaining Cap (Long Life)	1
18	C1012	Spacer - Machine	1
22	C1016	Locking Nut	1
23	C3045012	Wrench for Electrode	1
24	C1509	Extractor for Swirl Ring	1

Please Note: Configuration above only to be used on the Jasic Cut 160

JASIC Plasma Cutting Safe Working Practice



Safety glasses must be worn at all times in addition to welding mask



Oil free leather gloves and spats must be worn



Close fitting/protective clothing to cover arms and legs must be worn



Respiratory protection devices may be required



Long and loose hair must be contained



Sturdy footwear with rubber soles must be worn



A welding mask with shade number 11 protective filters must be worn



Hearing protection may be required when cutting thick material

PRE-OPERATIONAL SAFETY CHECKS

- Locate and ensure you are familiar with all machine operations and controls.
- Ensure material to be cut poses no hazard. Consult the manufacturers' Material Safety Data Sheets (MSDS) for specific technical data and precautionary measures for any materials or coatings on materials cut with this equipment.
- Check workspaces and walkways to ensure no slip/trip hazards are present, ensure the work leads and hoses do not create a trip hazard.
- Ensure the work area is clean and clear of grease, oil and any flammable materials.
- Keep the equipment, work area and your gloves dry to avoid electric shocks.
- Ensure the gloves, handpiece and work leads are in good condition.
- Ensure other people are protected from flashes by closing the curtain to the welding bay or erecting screens.
- Start the fume extraction unit before beginning cutting operation. Ensure machine is used in a well-ventilated area if not used in a welding bay.

OPERATIONAL SAFETY CHECKS

- Ensure machine is correctly set up for current and airflow.
- Ensure work return earth cables make firm contact to provide a good electrical connection.

ENDING OPERATIONS AND CLEANING UP

- Switch off the machine and fume extraction unit when work completed.
- Turn off the air supply and hang up handpiece, hose and welding cables.
- Leave the work area in a safe, clean and tidy state.

DON'T

- Do not use faulty equipment. Immediately report suspect equipment.
- Do not weld or cut containers that have held combustible liquids or gases.
- Do not heat or cut metals coated with or containing materials that emit toxic fumes, unless coating is removed from the work surface.
- Never leave the machine running unattended.

POTENTIAL HAZARDS AND INJURIES

- ⇒ Electric shock
- ⇒ Noise
- ⇒ Body burns
- ⇒ Compressed air
- ⇒ Radiation burns
- ⇒ Fumes
- ⇒ Noxious gas
- ⇒ Flying sparks and falling slag

This safety page does not necessarily cover all possible hazards associated with plasma equipment safety and should be used in conjunction with the operating manual along with other references such as risk assessments. It is designed as a reminder to users prior to equipment use and as a guide to be used to compliment operator training.



Before starting any welding or cutting activity ensure that you have suitable eye protection and protective clothing. Also take the necessary steps to protect any persons within the welding area.

Notes for cutting operation

1. Do not touch the hot workpiece with bare hands to avoid burning.
2. It is recommended not to ignite the arc in the air if not necessary, for it will shorten the lifespan of the electrode and nozzle of the torch.
3. It is recommended to initiate the cutting from the edge of the workpiece unless penetration is needed.
4. Ensure spatter comes from the bottom of workpiece while cutting. If spatter comes upwards from the top of workpiece, it indicates that the workpiece has not been fully cut through. This could be due to not enough power or the cutting torch is moved too fast.
5. For cutting a round or shaped piece or to meet precise cutting requirement, a stencil board or other tools are needed.
6. It is recommended to pull the cutting torch while cutting.
7. Keep the nozzle of the cutting torch upright over the workpiece and check if the arc is moving with the cutting line. Do not bend the cable too much, step on or press upon the cable to avoid restricting the air flow. The cutting torch may be burned if the air flow is too low. Keep the cutting cable away from sharp edges.
8. When the workpiece is nearly cut off, slow down the cutting speed and release the torch trigger to stop cutting.
9. Check the torch consumables frequently to prolong the life.
10. Always ensure the correct consumables are fitted in the torch. Incorrect items may cause damage to the torch or machine.
11. It is recommended that a torch of maximum length of 6 metres is used. If the torch cable is too long, the performance of this cutting machine such as arc ignition will possibly be affected due to the fact that the inner resistance of the cable will reduce the output voltage.

Please Note:

- **Your air supply must be free of moisture, water, oil or any other contaminants. Excessive water or oil may cause double arcing, excessive electrode/tip wear or even torch head failure. Contaminants will also cause poor cut quality.**
- **When starting the arc, ensure you keep the pilot arc time to a minimum to avoid excessive wear on the cutting tip.**
- **Do not overtighten the electrode when fitting a new set of consumables. Over tightening may cause damage to the internal torch head thread so that the cutting tip will not seat correctly.**
- **Only use the supplied or recommended 'O' ring lubricant or grease for your plasma torch head, using the wrong lubricant that cannot withstand high temperatures could cause damage to the plasma torch head.**

JASIC Description of Stand-off Cutting

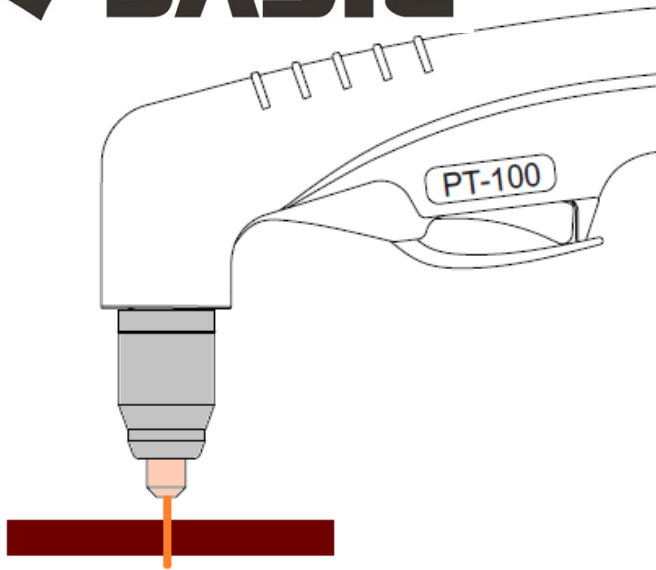

FREE HAND STAND-OFF CUTTING

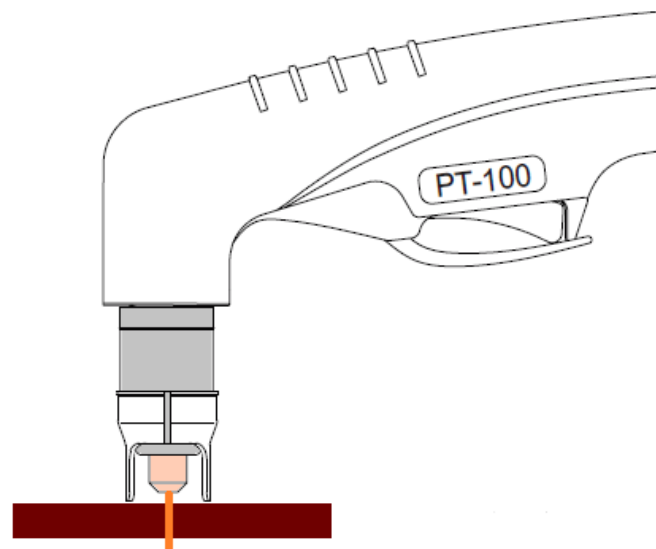

STAND-OFF GUIDE CUTTING

Stand-Off Cutting

The stand-off cutting technique is the process of holding the tip of the torch between 3-4mm from the workpiece to achieve the optimum cut.

Stand-off cutting requires a cutting tip that you need to ensure that the plasma machine's output amperage is matched to the amperage with the tip.

Depending on the application the operator may choose to hold the torch 'free hand' away from the plate or could choose to use a stand-off guide to help hold the torch away from the plate at a fixed height, also available are roller guides and circle cutting guide kits which can be very helpful in creating the cuts you want. To begin cutting you would place the torch above the work piece of about 3-4mm, and begin drawing the tip across the workpiece.

You should always start with the torch placed at the farthest point from you and then cut by pulling the torch towards you.

Make sure to keep the torch upright to the material being cut throughout the cutting process.

As you are cutting ensure you maintain a smooth and consistent travel speed to make a clean and precise cut.

There are 3 main reasons why plasma machine operators prefer to use the stand-off technique rather than drag tip cutting

- ⇒ It allows for a smoother movement of the torch above the material being cut without any part of the torch touching the material.
- ⇒ You can comfortably stand the torch while making the contouring process or following a certain pattern.
- ⇒ Because the cutting tip is not touching the material, this helps to prevent any blowback of molten material.



JASIC Description of Drag Cutting

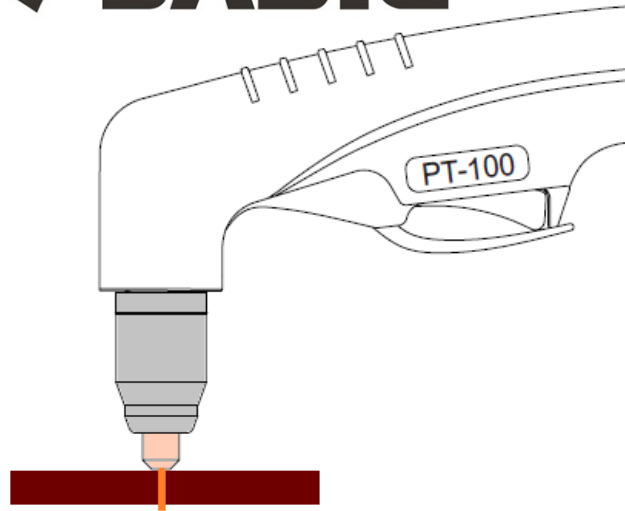

DRAG TIP CUTTING

Drag Tip Cutting

Drag tip cutting is the process of dragging the tip of the torch along the workpiece to cut the metal. This is often the easiest way to cut while minimizing heat input but usually only on cutting currents of 40amps and below. This technique works best when the material being cut is 5mm or less.

Drag tip cutting does require a 'drag' cutting tip and you need to ensure that the plasma machines output amperage is matched to the amperage with the cutting tip.

It can often be helpful to use a non-conductive straight edge to help maintain a straight cut.

Drag Shield Cap Cutting

The drag shield cap option allows the same technique to be used but having the cutting tip insulated (shielded) from the material being cut. Using a drag shield cap allows you to rest the torch (via the drag cap) on the workpiece while maintaining an optimal 2-3mm standoff without touching the cutting tip to the material for amperages 40amps and above. (When cutting at above 40amps, touching the tip to the work material will adversely affect your cut quality and consumable life).

When you start to drag cut, you would place the tip/cap of the torch on the workpiece and begin dragging (moving) the torch across the workpiece.

You should always start with the torch placed at the farthest point from you and then cut by pulling the torch towards you while making sure to keep the torch upright to the material being cut throughout the cutting process.

As you are drag cutting ensure you maintain a smooth and consistent travel speed to make a clean, precise cut.

The main benefits of drag cutting is:

- ⇒ Much easier for the operator because you don't need to maintain a distance between the cutting tip and the workpiece. You can simply drag the end of the plasma torch along a template or a straight edge. This process usually ensures a more accurate cut.
- ⇒ Drag cutting produces less spatter and blow back and improves the life of the front end torch parts.
- ⇒ Best cut quality for material of 5mm or less.

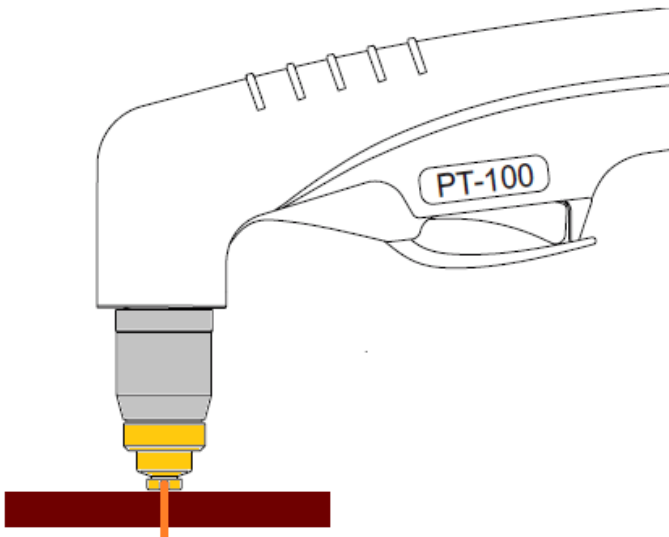

DRAG SHIELD CAP CUTTING



JASIC Plasma Cutting Techniques

Piercing

Piercing is the process in which a quick hole is made in the workpiece. Piercing is often just a starting hole that will be used to make a circular cut within the workpiece.

You can use standard cutting tips for piercing although ensure the plasma machines output amperage matches the cutting tips amperage rating. No accessories are required when piercing.

The thickness of the material to be pierced will need to fall in the proper amperage range for the machine and tip you will be using. There are two different techniques for piercing depending on the thickness of the workpiece. If the work piece is less than 2mm sheet metal, the torch should be held at a 15°-30° angle with the cutting tip touching the workpiece.

Begin by establishing the pilot arc, as soon as the pilot arc penetrates the workpiece, use a smooth, rolling motion to move the torch to a 90° (perpendicular) angle. At this point, the pierce has been created in the workpiece allowing you to begin the cutting process. If the material being cut is thicker than 2mm the torch should be held at a 90° (perpendicular) angle approximately 12mm or more above the workpiece.

Begin by establishing the pilot arc and slowly move the torch towards the workpiece until the cutting arc transfers.

Once the transfer has occurred, hold the torch still until the arc exits the bottom of the workpiece. Once the pierce has been made, the torch can be lowered to normal cutting height and the cutting process can begin.

Bevelling

Bevelling allows you to angle the edge of a flat plate or pipe to allow for deeper weld penetration.

This process is normally used for materials that are 9mm or thicker. You can utilize standard cutting tips for bevelling, again you need to ensure you utilize the correct plasma machine amperage to match the cutting tips used.

Ensure that the thickness of the material to be bevelled falls in the amperage range of the plasma machine and cutting tip that you will be using. If bevelling by hand, a roller and/or angle guide can be helpful in maintaining the consistent bevel face and the desired angle which is usually determined by the weld joint design.

The industry standard angle ranges are from 15°-45°. The cutting tip would normally be between 3–6mm from the workpiece.



JASIC Plasma Cutting Techniques

Gouging

Gouging creates a smooth, clean concaved groove within the material being gouged which is often weld ready. This process is primarily used for weld removal or back gouging.

Gouging has specific consumables and settings depending on the gouge you need to produce which include the gouging tip, shield cup and gas distributor that would be specific to gouging.

To begin the gouging process, hold the tip of the torch approximately 12mm from the workpiece angling the torch approximately 20°-40° to the surface, engage the pilot arc and once established slowly move the tip closer to the work piece until the main arc has transferred. Once the main arc is established, retract the tip until the distance from the work piece to the tip is approximately 15mm.

Make sure that you keep the tip of the torch angled approximately 20°-40° during this entire gouging process.

To create a narrow u-groove in the workpiece, the operator should maintain a constant, smooth travel speed.

With this technique the gouge created will be approximately 6mm wide by 6mm deep but this may depend on the gouging tip profile.

To create a wider groove, you can oscillate the plasma torch side to side in a half-moon sequence while maintaining a constant, smooth travel speed. The gouge created will be wider but not as deep. Due to the nature of the gouging process, lead covers, gouging deflectors and torch covers are some accessories that will help to protect the equipment used in the gouging process.

Gouging can be done on all conductive materials.

Before you start gouging, check the torch, consumables, and cables for excessive wear and damage. If the electrode, swirl ring or the cutting tip orifice shows signs of wear and tear, replace it with a new component that is sized correctly for your unit and application. Cutting or gouging with worn-out consumables only leads to poor cutting/gouging performance.

Use clean, dry workshop air (install a filter if necessary) and match pressure and flow requirements to those of the plasma cutter. Adjust the gas pressure on the machine according to the owner's manual. For torch leads longer than 6m, add 4 PSI for each additional 6m. Setting the pressure when the air is flowing through the torch will ensure that you have proper pressure and airflow while cutting.

JASIC Plasma Cutting Tips and Techniques

The below is just a few tips on how to get the best cut performance out of your Jasic plasma machine.

Before cutting always check the torch, consumables and cables for excessive wear and tear. If the electrode, air distributor or the cutting tip orifice shows signs of wear and tear then replace it with new consumables sized correctly for your Jasic plasma machine and application you are about to undertake. Cutting with worn-out consumables will only lead to poor cut quality.

Only use clean, dry compressed air (always ensure an air filter is installed), ensure you match the air pressure and air flow requirements to those of your Jasic plasma machine. Adjust the gas pressure on the machine according to the owner's manual.

Always set the air pressure when the air is flowing through the torch, this will ensure that you have proper pressure and airflow while cutting. For torch leads longer than 12m, it is common to increase the air pressure by approximately 10 PSI.

Always use the right tip for your amperage setting. A lower amperage tip has a smaller orifice which maintains a narrow plasma stream at lower settings. Using a 40-amp tip at an 80-amp setting will distort the tip orifice and will reduce consumable life. Using an 80-amp tip on the lower settings will not focus the plasma stream as well and lead to a wider kerf.

Use extended tips to reach out further for cutting in corners, using patterns or in tight areas.

It is generally best to start a cut from the edge of the plate, hold the torch at 90° to the edge of the workpiece. Press the trigger and pause at the edge until the cutting arc has completely cut through the material being cut.

When pierce cutting, start the pierce just off the cutting line in the area of unwanted metal. Angle the torch slightly to direct blowback molten material away from the torch tip (which will greatly extend tip life). Once the arc pierces the metal, return the torch to the perpendicular position and start moving the torch.

When possible, pull the torch toward you rather than pushing it away from you. On thicker materials it is common to tilt the torch back (away from the cutting direction) about 5°-10° to help minimize dross build up.

When you are cutting at the correct speed, the plasma arc under the workpiece should trail the torch at a 5°-10° degree angle. An arc that trails straight up and down can indicate that your travel speed is too slow, which can produce a cut that is wider than desired, along with an increase in amount of excess dross. An arc with a shallow trail indicates you're moving too quickly and most likely you will not be severing the metal cleanly. For straight line cutting, use a non-metallic straight edge. Using a piece of mild steel for example as a straight edge can pull the arc towards it offering a poor cut quality or possibly causing double arcing. A roller guide can prevent this.



JASIC Plasma Machine Gas Supply - Compressed Air

Only use compressed air with the Jasic plasma machines

Please Note: NEVER USE OXYGEN

Compressed Air Supplies

Sizing the appropriate compressor to use with your plasma cutting machine is as important as supplying the correct mains power supply.

To get the best out of your plasma cutter you need to supply it with an adequate air supply. The below are suggested questions that need to be considered when specifying an air compressor.

- What is the maximum required operating pressure of the plasma cutter?
- What is the maximum required CFM usage of the plasma cutter?
- Does the machine need to be portable or stationary?
- What type of drive do you require? Electric motor or diesel engine?
- What receiver tank size will be needed?
- Generally 3 phase compressors are considered a better option than single phase compressors.



The accessories used with the compressor are also important, providing the correct air pressure, air flow which is moisture and oil free is crucial in ensuring that your plasma will give you quality cuts.

Air Hose: Remember to select the correct bore size, considering demand and length.

Filters: Remove contaminants e.g. water and oil thus prolonging plasma torch consumable life.

Dryers: Refrigerant dryers, high efficiency heat exchangers.

Regulators: Allow adjustment to optimum pressure for efficient use of your plasma cutter. Regulate your system to the pressure you need.

Couplings: Heavy air use tools/equipment may need high flow couplings. Size matters.

**PLEASE NOTE: Using oxygen in a plasma torch that is designed for air cutting can cause a serious fire and injury.
Be careful and always follow the manufacturer's instructions.**



Wilkinson Star Limited
Shield Drive
Wardley Industrial Estate
Worsley
Manchester
United Kingdom
M28 2WD
Telephone: 0044 (0)161 728 7900
Email: sales@wilkinsonstar.com